

2nd Quarter 2005

OMNI provides (13) Over/Unders, (3) Side by Sides, and (4) Straight Line Rack Indexing Systems to Visteon in Connersville, Indiana. These are for their new dunnage program designed to reduce material handling costs.

Additional information on page 2.

7-Position Straight line Indexer

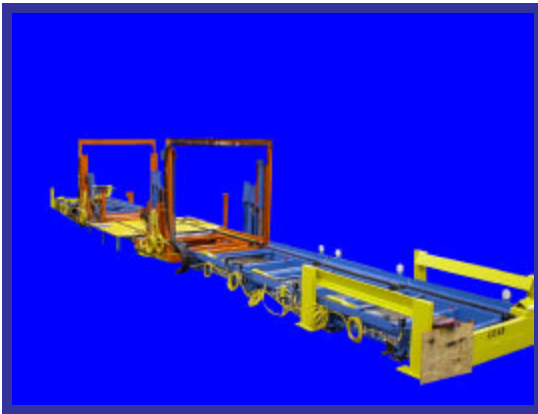

3-Position Over/Under Indexer



Inside this issue:

Visteon Container Handling	2
TRW Boot Seal Press	3
Tower End Effector Tool	3
Company Overview	4

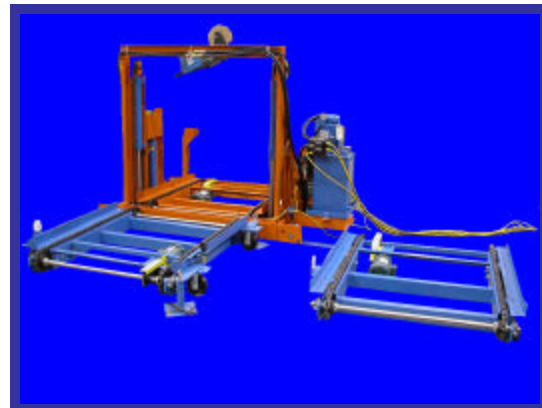

3-Position Side by Side Indexer

7-Position Straight Line Indexer

The 7-Position Straight line Indexer has three inbound accumulation zones, two operator positions and two outbound accumulation zones. The operator stands on a platform between the two lift and tilt stations shown in the picture. The operator pulls parts from the left-hand container, performs an assembly operation and then puts the finished parts in the container at the right-hand side. When the left hand container is empty (and the right hand container is full), the operator steps off the platform (which has safety mats), pushes a cycle button and the system automatically indexes the containers. The 20" lifts and 60 degree tilts allow each operator to ergonomically adjust the containers.



3-Position Over/Under Indexer

This system is fork truck loaded with full containers on the lower inbound level. The full container indexes out to the operator position. Here the operator can lift and tilt the container for ergonomic access to the parts. When the last parts are removed from the container, with the push of a button, it is automatically raised up and indexed back out the top level for fork truck removal. Once the carriage returns to the lower level a full container automatically indexes into the operator position. A unique feature of this system is the "OMNI Yoke" elevator. It utilizes hydraulic cylinders and a yoke mechanism to achieve the vertical elevator travel.



3-Position Side-by-Side Indexer

The side-by-side system uses the same basic lift and tilt mechanism as in the straight line system. Full containers are fork truck loaded onto the inbound conveyor where they are indexed into the operator position. As with all the other systems, the operator has control of the ergonomic position of the container. Once empty, the complete lift and tilt station shuttles to the right where the empty containers is indexed out for fork truck removal. The shuttle automatically returns to accept the next full container.

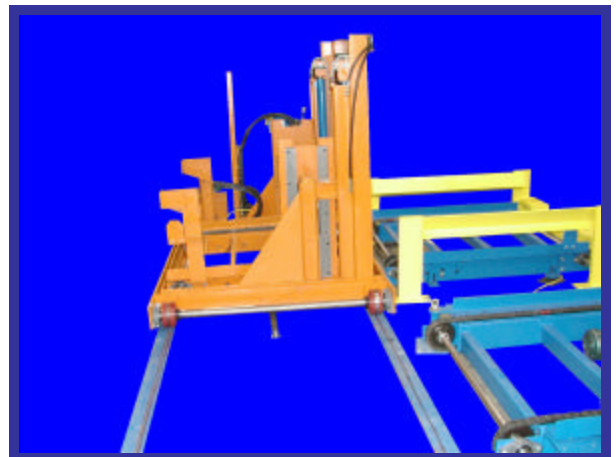

TRW Boot Seal Press

The equipment was built with a Pneumatic seal press. The press installed a rubber boot over the ball stud in a steering linkage component. The press had two complete separate sets of tooling that would accommodate nine separate parts. The press was PLC controlled and had a light curtain with blanking for tie rod knuckles with longer arms.

A metered amount of grease was injected into each knuckle through a zerk in the knuckle seal. Press pressure could be varied, depending on the part being run.

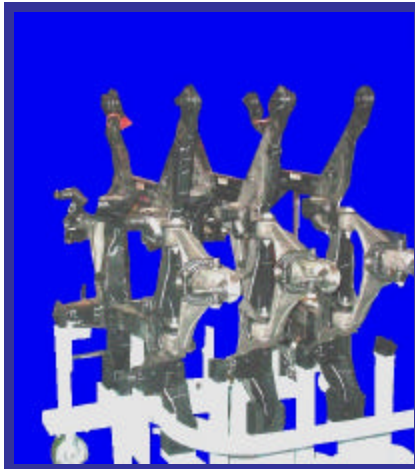
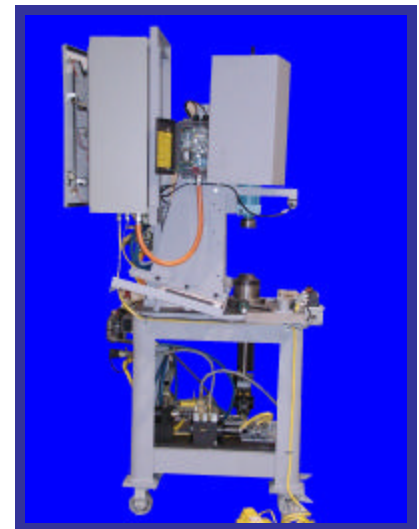
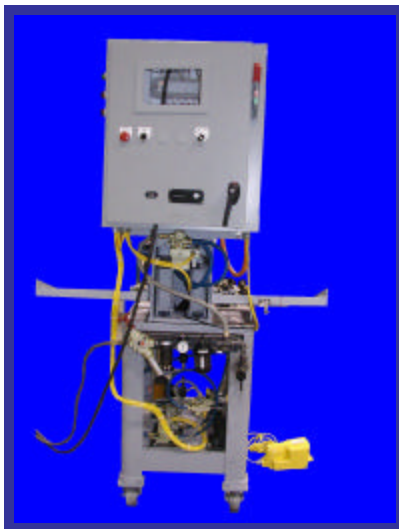
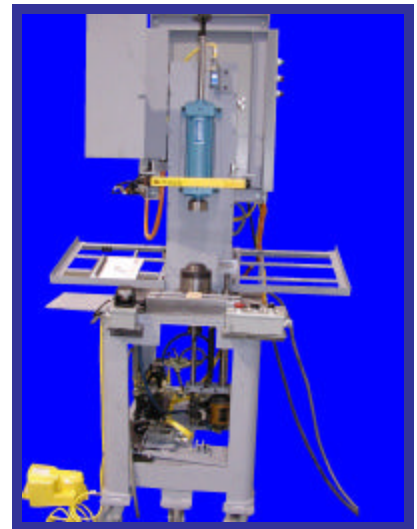

Tower End Effector Tool

Carts held four front cradles in a specific attitude. A Unified bridge crane with a hoist was used to lift cradles out of the transport carts. The End Effector tool was used to hold the cradle and position it in a specific attitude prior to loading into secondary assembly equipment.

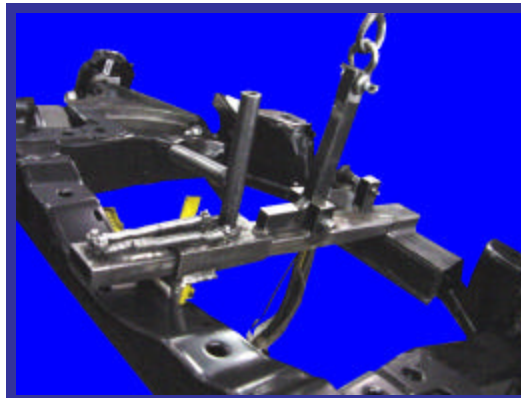



"OMNI is committed to provide continuous quality improvement and solutions that will increase the satisfaction of our customers with efficiency, first run success, on time delivery and zero defects."

WE'RE ON THE WEB!
VISIT US AT
WWW.OMNI-TSI.COM

OMNI Technical Services Inc. is a single source solution for part, rack and pallet handling problems. We offer a variety of standard and patented systems to help companies reach their goals of higher production and lower costs.

OMNI is located in St. Johns, Michigan. Our engineering professionals have many years of experience in systems design. Our 45,000 ft. facility provides the manufacturing capabilities necessary to meet volume production and delivery requirements.

Established in 1978 to serve manufacturing industries, OMNI has devoted years to the design of pallet handling systems and many more to test and develop them. Through this, we have achieved a proven line of ergonomic products and 21 years ago we started an in-house division. This division, **OMNI Ergonomics**, with its specialized experience and engineering can better handle and integrate your ergonomic applications.



OMNI Ergonomics

Division Of OMNI Technical Services, Inc.

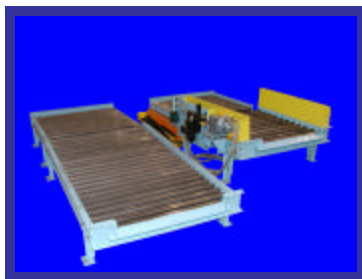

5-position Side x Side
with Lift Table

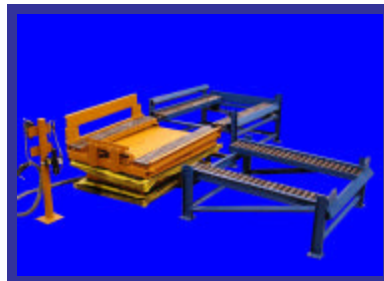

3-position Side x Side with
Lift, Tilt and Rotate



Lift and Tilt with Conveyor